



IN THIS EDITION

Preface	p 1
Volkswagen from an economical point of view	p 1
BBT travels	p 1
BBT on the market	p 1
New products	p 1-6
No longer available	p 6

PREFACE

Each year again, about the same time, the season is coming which should call summer, but if this will honour its name, that's still a question. For us in Western Europe, we're still remembering the sad summer of 2007. Coordinators of meetings think back to their top days, slogging through the mud. Hopefully the summer of 2008 will take its revenge, May was beautiful, but June hasn't succeeded to continue the nice weather... let's hope that July and August will bring some nice days which we need to get our beloved Volkswagen on the road. The more they drive, the greater the impact on the trade of spare parts on the one side and on the general (car) way of living at the other hand. "Sunshine, VW drives", that would be a nice name for a song...

Bob

BBT TRAVELS

We're represented at most of the summer festivals. Do you need something? We can bring it along. Just give us a call or mail to Pascal (pascal@bbt4vw.com) a simple question should be enough. Afterwards you can take a look at the pictures on our website under chapter... BBT travels of most of the Volkswagen meetings.

NEW PRODUCTS

#0005-5 Bumper, '74-, rear, chrome

This chrome bumper is of the same quality as all our other Brazilian bumpers. It is used on beetles after 1974 and it goes along with the front bumper BBT #0005. Sold per piece and stock is already available.

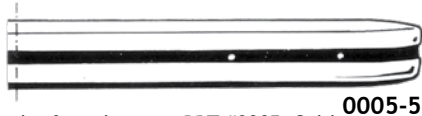

0005-5

#0101-300 Fender beading kit, Type 3, Notchback #0101-301 Fender beading kit, Type 3, Fast-en Squareback



As from now the correct fender beading kits are available. We've taken these kits into our program because of the special form of the fender beading seals. Sold per set for 1 car and already some in stock.

DE VOLKSWAGEN WERELD ECONOMISCH BEKEKEN

The rates of exchange are going wrong, but that's ancient history, the booming industries, where our spare parts are made, aren't also nothing new. However a new fact is coming up, someone nobody has counted on. Due to the expensive raw materials, the high prices of gas and diesel fuel and a standard of living where the common working family has difficulties to make both ends meet, there is an increasing burst of discontented consumers (and small producers). Are we already feeling the results of the globalization, which took place the past 15 years at top speed? According to us the problem is that there are only a few people left who are controlling everything and the rest of the world has got to follow! I especially think of the oil, but also of steel and all other ores. Have we seen the final of it? I don't think so. Prices of fuel can easily double, if things are going on the same way, probably the standard of living will take a considerable dip. If this will harm our hobby and industry we've got to abide the consequences. In my opinion people will cling to those things they know the best, and let our hobby of Volkswagen be part of it... Welcome to the 21st century, it's turning at full speeds.

BBT ON THE MARKET

The dollar is stagnating the last few months, have we seen the bottom? It's still a question, of course. What we definitely know is that many of our main suppliers have increased their prices considerably. We're trying to compensate these price rises with items that we've been able to buy cheaper, mainly by stocking large quantities.

- #0019-200 Bumper bracket, left, front, T2, '59-'67
- #0019-210 Bumper bracket, right, front, T2, '59-'67
- #0019-250 Bumper bracket, rear, T2, '59-'67
- #0052-200 Mounting kit front bumper, Type 2, '59-'67
- #0052-210 Mounting kit rear bumper, Type 2, '59-'67



These bumper brackets are for Type 2 from 1959 till 1967, left and right for the front is different, there the same at the rear. The quality and the fit is like original. Due to the increasing demand after these brackets, we have taken them into our program. We sell now also the mounting kits to assemble these bumpers on the brackets. Sold per piece and already some in stock.

NEW PRODUCTS

- #0136-100 Rear valance 'H', Type 1, -'55, (-Ch. 1-929745)
- #0136-101 Rear valance 'H', Type 1, '55-'60, (Ch. 1-929746 - 1960)

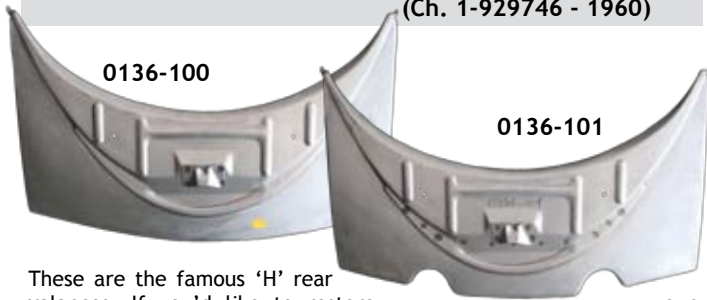

These are the famous 'H' rear valances. If you'd like to restore your beetle even better, you need this valance. Originally they are hardly to be found and unaffordable. The quality which we have taken in our program is hand made of 1 mm thick steel and the best quality available. The difference between these 2 models is that until July 1955 there were no facilities for the exhaust pipes, as they came under the rear valance (for the USA models till the end of May 1955). As from August 1955 (ch. 1-929746) all beetles had 2 exhaust facilities in the rear valance. The famous 'H' rear valance has been used originally till 1960. Sold per piece and stock already available.

- #0404-250 Clip for rocker moulding, T3, -'66 (1)
- #0404-251 Clip for rocker moulding, T3, '67- (1)



During many years we had the mouldings for Type 3, but we didn't have any clips for the rocker mouldings. That's why we have taken them into our program. There are 2 models till -'66 (wide mouldings) and '67- (small mouldings). They are sold per piece and stock is already available.

- #0440-09 Emblem 'VW', Type 2, -'67, stainless steel (polished)

It's finished with rusty emblems! As from now we sell them in stainless steel at the price of steel with a special perfect fit and studs which are long enough to assemble the emblem, even with the thickest paints and/or filler. They are polished with high-gloss paint and they shine as chrome. Sold per piece and stock is already available.



- #0496-100 Spatlappen Type 1, met VW embleem / wit



Vanaf nu hebben we ook witte spatlappen met zwart VW logo voor Type 1. Deze worden per paar verkocht met montage steunen voor Type 1. Verkocht per paar en reeds stock voorradig.

- #0214-000 Running board mats, black (pair)
- #0214-001 Running board mats, ruby red (pair)
- #0214-002 Running board mats, dark green (pair)
- #0214-003 Running board mats, light green (pair)
- #0214-004 Running board mats, dark blue (pair)
- #0214-005 Running board mats, light blue (pair)

- #0198-901 Fender beading, ruby red (1 roll)
- #0198-902 Fender beading, dark green (1roll)
- #0198-903 Fender beading, light green (1roll)
- #0198-904 Fender beading, dark blue (1roll)
- #0198-905 Fender beading, light blue (1roll)
- #0198-906 Fender beading, ivory (1roll)



These running board seals and fender beadings are from the same manufacturer and therefore the colours correspondent 100% to another. Other colours which we sold already, will leave our program. We have taken these into our assortment to guarantee to our customer a better delivery/quality and price. Sold per set for 1 car. Stock already available.

- #0438-275 Bolt for engine lid support spring, T2, '64-'92

Besides the engine lid support springs and leading we have now also the special bolt to fix this spring. Due to the special form of this bolt it isn't for sale in the usual shops. That's why we have taken it into our program. Sold per piece and stock already available.



- #0517-700 Vent window assembly, T1, '56-'64, left/ chrome
- #0517-710 Vent window assembly, T1, '56-'64, right/ chrome
- #0517-800 Vent window assembly, T2, -'67, left / white
- #0517-810 Vent window assembly, T2, -'67, right / white



Good used vent windows are the more and more difficult to find, that's why we have taken them in our program. This production is of excellent quality and delivered with assembled window and vent window lock. It's ready for assembly in your door. Sold per piece and stock already available.

NEW PRODUCTS

- #0492-110 Fuel tap, Type 1, '55- (8mm)
- #0492-111 Fuel tap, Type 1, '55- (6mm)
- #0492-112 Fuel tap, -03/'55 (8mm)
(Type 1, Type 2 and Porsche 356)
- #0492-113 Fuel tap, -03/'55 (6mm)
(Type 1, Type 2 and Porsche 356)
- #0492-114 Fuel tap, T2, 03/'55-07/'67 (6mm)
- #0492-115 Filter for fuel tap, Type 1
- #0492-116 Filter for fuel tap, Type 2
- #0492-117 Gasket filter bowl for fuel tap, -03/'55
- #0492-118 Filter bowl for fuel tap, -03/'55
- #0492-119 Filter in bowl for fuel tap
- #0492-120 Gasket for fuel tap filter
- #0492-121 Nut for fuel tap

- #0492-130 Fuel tap, Porsche, 03/'55-08/'61
(Chas. 53526 (coupe) 60815 (cab.) - 356BT5)
- #0492-131 Fuel tap, Porsche 09/'61-03/'66
(356BT6 - 356C)
- #0492-132 Gasket filter bowl for fuel tap, Porsche 356,
03/'55-03/'66
- #0492-134 Filter bowl for fuel tap, Porsche 356,
03/'55-03/'66 (50mm)
- #0492-135 Nut for fuel tap, Porsche 356, 03/'55-03/'66
- #0492-136 Filter for fuel tap, Porsche 356, 03/'55-03/'66
- #0492-137 Gasket filter bowl for fuel tap, Porsche 356,
03/'55-03/'66
- #0492-138 Gasket (cork) in fuel tap, Porsche 356,
03/'55-03/'66

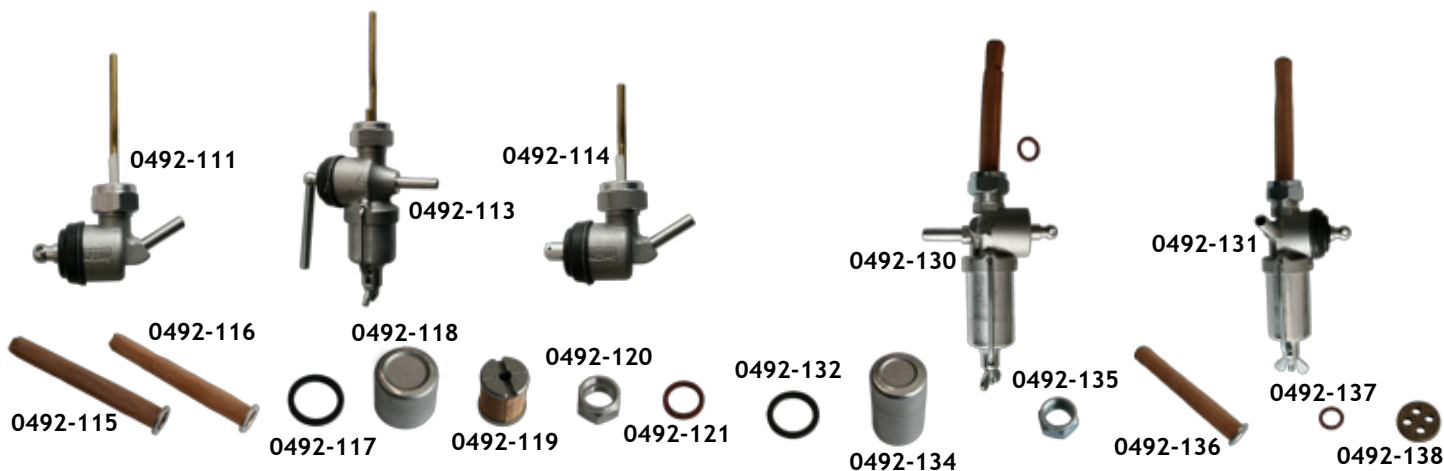

As from now we sell the entire assortment of fuel taps, also with the spare parts to repair your old fuel tap. Nevertheless we recommend to install a new one to avoid leaks. These fuel taps are sold without filters and gaskets, so you've got to order them separately. Only those for Porsche 356 already a filter and a gasket. They are original and of perfect quality. Sold per piece and already some in stock.

#0573-100 Lap belt, black, universal, with E-mark(1)



This lap belt is a Universal 2-points belt. They are mostly used at the back seats, but you can use them also on the front seats. The belts are only for sale in black and they have the E-mark. So they are suitable for the technical control in all European countries. Sold per piece and stock is already available.

#0630-100 Headlight lens, KG, '61-'74 / Hella (1)

As the complete headlights for Karmann Ghia won't be available for a long time, we will in the future stock as much parts as possible separately, so that we can help the Karmann Ghia drivers further. This headlight glass is originally from Hella (Made in Germany) and is of perfect quality. Sold by piece and stock is already available.



#0704-050 Fixing plate on front axle rubber/body

This plate is fixed on the rubber of the front axle, where the body is assembled. This plate isn't bad normally, but it get's often lost on fully restorations. Then it's handy that you can simply buy it with BBT. It is original and galvanized. Sold per piece and stock is already available.



#0610-100 Seal around headlight lens KG (pair)

This seal has been assembled around the headlight lens of KG, like original. Sold by piece for 1 car and already some in stock.



#0616-55 Turn signal housing, left, T2, 08/'63-07/'67 #0616-56 Turn signal housing, right, T2, 08/'63-07/'67

0616-55



0616-56

These turn signal housings are perfect copies in chrome, which will make a good lighting. It's a very handy product, because originals and used ones are unfortunately difficult to find in a good state. That's why we have taken apart from the lenses also the housings in our program. Sold by piece and stock already available.

NEW PRODUCTS

#0890-135 Front floor pan, T2, '59-'67

0890-135

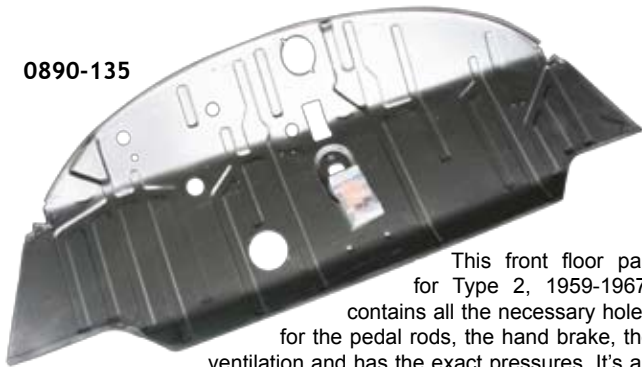

This front floor pan for Type 2, 1959-1967, contains all the necessary holes for the pedal rods, the hand brake, the ventilation and has the exact pressures. It's an ideal piece to replace the entire floor plate. A lose gas pedal support is included in the floor plate. Sold per piece and already some in stock.

#0890-58-1 Top hat section under ribbed floor, rear, T2, -'67

#0890-58 Top hat section under ribbed floor, front, T2, -'67

#0890-59 H-section under ribbed floor, T2, -'67

0890-58-1

0890-58

0890-59



The top hat section has also the U-profile like the BBT 0890-58, but it has been finished in such way that the plate at the rear is ready for assembly and doesn't need work anymore. They are of 1.2mm thick steel, they are provided with the exact holes and fit perfectly. We've taken the opportunity to replace also the BBT 0890-58 and BBT 0890-59 (from 1.5mm thick steel) by perfectly fitting parts, there where we use to have quality problems with, without considerable price modifications. Sold per piece and some stock is already available.

#1257-23 Brake fluid fill reservoir, T2, '68-'72

This small brake fluid reservoir serves to fill the big brake fluid reservoir on the master cylinder from the inside. It facilitates the filling and you don't need to be underneath the bus. Throughout years many buses don't have this filling piece anymore or it is broken. Now it's available again in a good quality. Sold per piece and stock is already available.

1257-23



#1301-005 Schock absorber, rear, IRS

This rear shock absorber is for all Type 1 with IRS and have the standard height. The big difference is that they have underneath a bushing i.o. a single eye, therefore one should make it do in the past and mostly it didn't work good. So as from now we have the exact shock absorbers for your beetle. Sold per piece and stock is already available.



#0890-385 Rear valance, Type 2, -'55, (complete) - Barndoor

#0890-386 Rear valance, Type 2, '55-'65, (complete) - Church key model

#0890-387 Rear valance, Type 2, '66-'67 (complete)

0890-385



0890-386



0890-387



These rear valances for buses are hand made from 1 mm thick steel. They are copied from originals and they fit perfectly. We've taken all the models for the Splitbus in our program, because good used and original ones are hardly to be find and unaffordable. Sold per piece and already some in stock.

#1150 Hupcap puller

This little tool pulls the hub cap from the wheel, it fits in the 2 holes, which are foreseen in the hub cap. As it is such a small tool, it get's often lost and due to wrong assembly the hub caps can get damaged. Now we have them in our program and they are originally from Volkswagen. Sold by piece and stock is already available.

1150

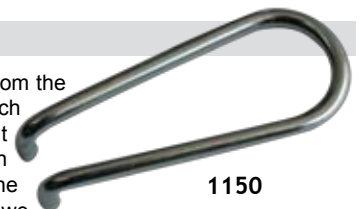

#1270-999 Disc brake, T1 + T3 (no holes)

#1281-999 Rear brake drum, 1300, '68-(no holes)

This disc brake and brake drum are not provided with the holes for the wheel bolts, therefore each pattern the customer needs, can be bored. It can be bored by our services or it can be done by yourselves. Sold per piece and stock will be available +/- in the middle of June.



#1319-100 Top shock bolts, Type 1, 08/'49-07/'62 (2)

These top shock bolts are for original front axles from 08/'49 (ch. 1-117 054) till and including -07/'62 (ch.4 846 835) they fix the shock absorbers at the top of the front axle. The difference is that this bolt is M12 and the part of the wire is only M8. For the later models the bolt are M12 everywhere. So for those people who are still working with their original front axle, this bolt is the only correct one to be used. Sold per set for 1 front axle. Already some in stock.



NEW PRODUCTS

#1362-3 Spindle nut left, T1, 08/'65-
#1362-4 Spindle nut, right, T1, 08/'65-

1362-3



1362-4

As from now we have also this type of nuts to fix on your disc or drum. They are used from 08/'65 till the end of the production. Sold per piece and stock is already available.

#1515-1 Pressure plate strengthened, 200mm (1700lb)

When assembling engines with a higher power than original, you can get problems with the flange of coupling, it will slip faster. As the original pressure plates aren't foreseen to transmit such powers, and therefore the pressure on the flanges of coupling isn't big enough. With the Kennedy (KEP) pressure plate, you can solve this problem. The pressure power of the KEP pressure plate is 80 % higher than original. The pressure plate can be used on all models. Kep tests and balances each coupling before they leave the factory, it can only benefit the quality. Sold per piece and stock already available.



#2906-100 Headliner, Type 1, '47-'52, cotton / beige
#2906-101 Headliner, Type 1, '53-'60, cotton / beige
#2906-102 Headliner, Type 1, '61-'62, cotton / beige
#2906-103 Headliner, Type 1, '63, perforated / white
#2906-104 Headliner, Type 1, '63, non-perforated/ white
#2906-105 Headliner, Type 1, '64-'67, perforated / white
#2906-106 Headliner, Type 1, '64-'67, non-perforated/ white
#2906-107 Headliner, Type 1, '68-'72, perforated / white
#2906-108 Headliner, Type 1, '68-'72, non-perforated / white
#2906-109 Headliner, Type 1, '73-, perforated/ white
#2906-110 Headliner, Type 1, '73-, non-perforated / white

#2906-200 Headliner, T1, '47-'55, with sunroof, cotton / beige
#2906-201 Headliner, T1, '55-'57, with sunroof, cotton / beige
#2906-202 Headliner, T1, '58-'62, with sunroof, cotton / beige
#2906-203 Headliner, T1, '63, with sunroof, perforated / white
#2906-204 Headliner, T1, '63, with sunroof, non-perforated / white
#2906-205 Headliner, T1, '64-'67, with sunroof, perforated / white
#2906-206 Headliner, T1, '64-'67, with sunroof, non-perforated / white
#2906-207 Headliner, T1, '68-'72, with sunroof, perforated / white
#2906-208 Headliner, T1, '68-'72, with sunroof, non-perforated/ white
#2906-209 Headliner, T1, '73-, with sunroof, perforated / white
#2906-210 Headliner, T1, '73-, with sunroof, non-perforated/ white

#1415-050 Swing axle tube packing, 08/'58- (1)
(Type 1 ch. 2 078 055-)

This plastic tube packing between the swing axle and the gear-box housing, is an indispensable part for the swing axle. If this part is broken or missing, the gear-box housing and the swing axle can get seriously damaged. Prevention is better than cure and therefore we've taken it into our program. This packing is original and has the perfect fit for all models from 08/58. Sold per piece and stock is already available.



#1493-056 Bolts for ring and pinion IRS (9mm) / 8 pieces

These 8 bolts fix the crown wheel. Due to the special wire and hardness of this bolt, it is not available in the usual commerce, 9mm and 34mm. This long version is for IRS gear boxes. Sold per set of 8 pieces.



#1651 Engine case hardware kit

1651



This hardware kit has been put together specially for the new engine cases. Because these engine cases are empty, we have taken this kit into our program. It contains the oil pistons, springs, stops but also the spring plate cap for the oil filling (underneath) with seals and also some cylinder studs to assemble the oil pump/cooler etc. Sold per set for 1 engine case and stock already available.

#2810 Steering wheel VDM, T2, -'67
#2811 Steering wheel ROMETSCH, T2, -'67



2810



2811

After the introduction of these Rometsch and VDM steering wheels for type 1, -'59, we have let them made also for type 2, -'67. They are just the same, only they are foreseen with a nave, which makes that the steering wheel gets a bit higher, so that you don't come against the dashboard. Sold by piece and stock already available.

NEW PRODUCTS

#2907-100 Headliner, KG, '56-'57, cotton/ beige
 #2907-101 Headliner, KG, '58-'62, cotton / beige
 #2907-102 Headliner, KG, '63-'74, perforated / white
 #2907-103 Headliner, KG, '63-'74, non-perforated / white

#2908-100 Headliner, T3 Variant, '61-'73,
 perforated / white
 #2908-101 Headliner, T3 Variant, '61-'73,
 non-perforated / white
 #2908-150 Headliner, T3 Variant, '61-'65,
 with sunroof, perforated / white
 #2908-151 Headliner, T3 Variant, '61-'65,
 with sunroof, non-perforated / white
 #2908-152 Headliner, T3 Variant, '66-'73,
 with sunroof, perforated / white
 #2908-153 Headliner, T3 Variant, '66-'73,
 with sunroof, non-perforated / white

#2908-200 Headliner, T3 TL, '66-'73, perforated / white
 #2908-201 Headliner, T3 TL, '66-'73,
 non-perforated / white
 #2908-250 Headliner, T3 TL, '66-'73,
 with sunroof, perforated / white
 #2908-251 Headliner, T3 TL, '66-'73,
 with sunroof, non-perforated / white

#2908-300 Headliner, T3 N.B., '63-'67, perforated / white
 #2908-301 Headliner, T3 N.B., '63-'67,
 non-perforated / white
 #2908-350 Headliner, T3 N.B., '63-'67,
 with sunroof, perforated/ white
 #2908-351 Headliner, T3 N.B., '63-'67,
 with sunroof, non-perforated / white

#2925-100 Headliner padding kit with bows,
 T1, (6st), 122cm

2906-xxx

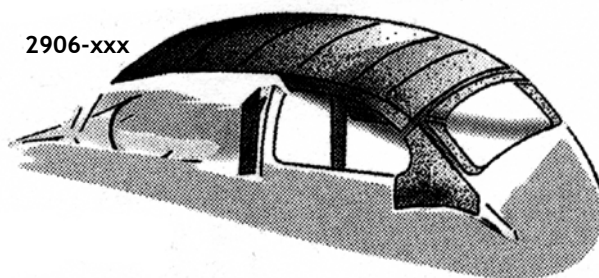

2907-xxx



2908-xxx

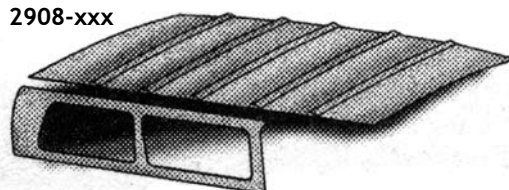

After expansion of our collection headliners for Type 2, we have now also the models for Type 1 / Type 3 and KG in stock with or without sunroof. The difference with the actual EASYINSTALL model is, that it is like original, so not in 1 piece, but in different pieces with attached eventual seals, as it should be. For each model there is already a small stock available. Sold per piece.

NO LONGER AVAILABLE

0198-2	1331-1	2771
0198-3	1331-2	3210
0198-4	1470	8958
0215-1	1612-050-18	9002
0216-1	1855	9412
0220	2105	9851
0514-33	2552	9861
1076-4	2596	

Price modifications are indicated on the pricelist itself!

